



# CSC01 CURRENT SHARE CIRCUIT

## Features

- Current Sharing Module for Parallel
- Voltage Droop Methods
- No Sharing Pin Connection Requirement
- No Tantalum Capacitor Inside
- Wide Input Voltage Range
- Wide Operating Temperature Range
- DIP-24 Package
- External Sense Resistor
- 1.25"x0.8"x0.5" Size Meet Industrial Standard



## PART NUMBER

Series	Type
CSC	XX
Current Share Circuit	01 : One Set, Pin Type

Part Number Example:

**CSC01:** CSC Series with Pin Type, One Set for Parallel

## TECHNICAL SPECIFICATIONS

(All specifications are typical at nominal input, full load at 25°C unless otherwise noted.)

### INPUT CHARACTERISTICS

PARAMETER	NOTES and CONDITIONS	Device	Min.	Typ.	Max.	Units
Input Voltage	Continuous	All	11		60	V <sub>dc</sub>
Operating Ambient Temperature		All	-40		85	°C
Operating Case Temperature	At the center part of case plate	All	-40		100	°C
Storage Temperature		All	-55		105	°C
Cooling	Natural convection	All				

### GENERAL SPECIFICATIONS

PARAMETER	NOTES and CONDITIONS	Device	Min.	Typ.	Max.	Units
Weight		All		15.9		g
Dimensions		All	1.25X0.80X0.50 Inches (31.8X20.3X12.7mm)			
Case Material	Non-Conductive Black Plastic					
Base plate Material	Non-Conductive Base					
Potting Material	UL 94V-0					
Pin Material	Base: Copper with Steel Plating: Barrel Tin					
Humidity	95% RH max. Non Condensing					
Application Note Link	<a href="#">Application Note Link</a>					

**PDF700S for Example**

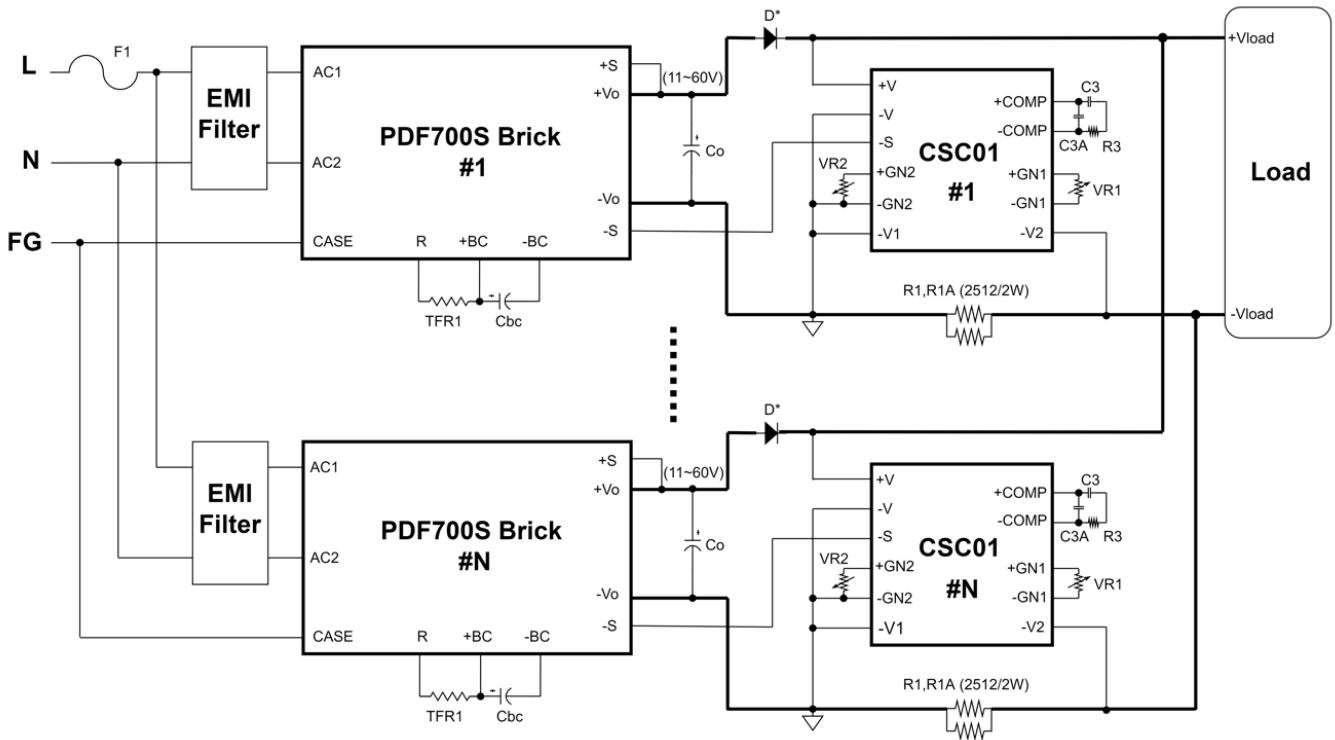

Please refer to the App Notes for detailed operation.

## MECHANICAL SPECIFICATION

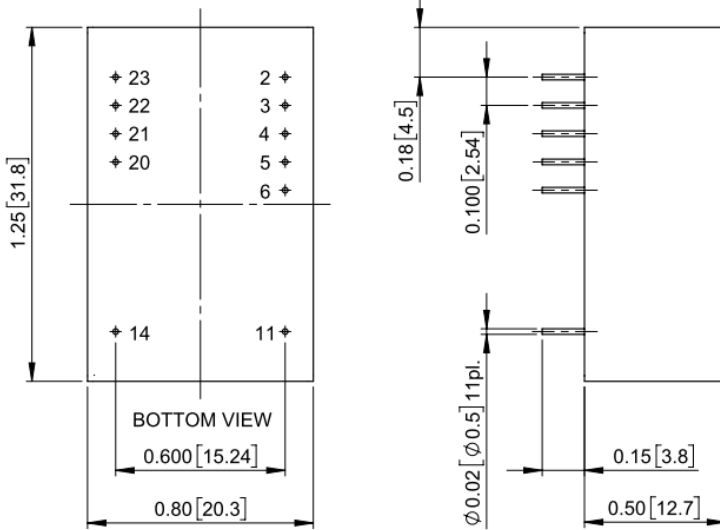

All Dimensions in Inches[mm]

Tolerance Inches: x.xx=±0.02, x.xxx=±0.010

Millimeters: x.x=±0.5, x.xx=±0.25

Pin Connection

Pin	Function
2	-V1
3	-GN1
4	-GN2
5	-COMP
6	-S
11	-V
14	+V
20	+COMP
21	+GN2
22	+GN1
23	-V2

Note: Pin Size is  $\varnothing 0.02 \pm 0.002$  Inch [ $\varnothing 0.5 \pm 0.05$  mm]

PIN	Function		Description
2	-V1	-V1 Signal	Sense Resistor for Converter Side
3	-GN1	Voltage Adjustment	Adjust Full Load Output Voltage with VR1
4	-GN2	Voltage Adjustment	Adjust Null Load Output Voltage with VR2
5	-COMP	Feedback	Negative Feedback Compensation
6	-S	-Sense	Negative Output Remote Sense of Converter
11	-V	Ground	Ground
14	+V	Provide Bias	Power Supply Providing Bias to CSC01
20	+COMP	Feedback	Positive Feedback Compensation
21	+GN2	Voltage Adjustment	Adjust Null Load Output Voltage with VR2
22	+GN1	Voltage Adjustment	Adjust Full Load Output Voltage with VR1
23	-V2	-V2 Signal	Sense Resistor for Load Side